



LED Permanent Beacon 211 (base mounting)



LED Permanent Beacon 214 with integrated mounting bracket



Housing with CAGE CLAMP® connection

i TECHNICAL SPECIFICATIONS/ORDER SPECIFICATIONS:

	Base mounting 211	Bracket mounting 214
Dimensions (Ø x Height):	58 mm x 97 mm	58 mm x 123 mm
Housing:	PA-GF, high impact	
Lens:	PC, transparent; Ring: PC	
Connection:	CAGE CLAMP® technology max. 1.5 mm ²	
Cable entry:	Cable diameter max. 10 mm	Cable diameter 3-6 mm
Fixing:	Base mounting with flat seal	Bracket mounting incl. cable gland M12 x 1.5 mm
Life duration:	Up to 100,000 hrs	

Base mounting 211			
Voltage:	24 V AC/DC	115 V AC	230 V AC
Current consumption:	45 mA	25 mA	25 mA
red	211 100 75	211 100 67	211 100 68
green	211 200 75	211 200 67	211 200 68
yellow	211 300 75	211 300 67	211 300 68

Bracket mounting 214			
Voltage:	24 V AC/DC	115 V AC	230 V AC
Current consumption:	45 mA	25 mA	25 mA
red	214 100 75	214 100 67	214 100 68
green	214 200 75	214 200 67	214 200 68
yellow	214 300 75	214 300 67	214 300 68

TECHNICAL DIAGRAMS:

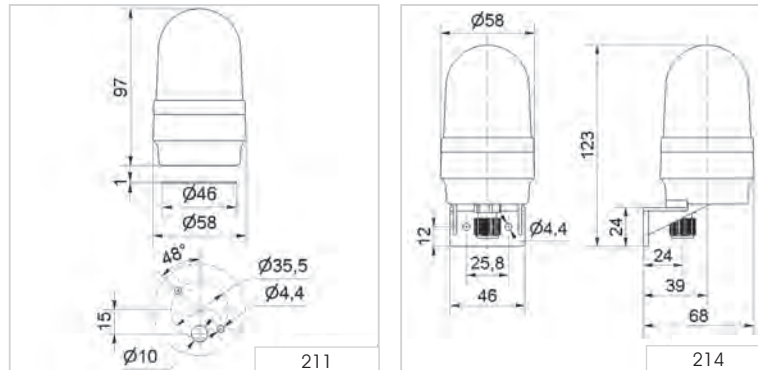

Signalisation index	
LED Permanent Light	3

