



LED Permanent Beacon 221 (base mounting)



LED Permanent Beacon 224 with integrated mounting bracket

**i TECHNICAL SPECIFICATIONS/ORDER SPECIFICATIONS:**

	Base mounting 221	Bracket mounting 224
Dimensions (Ø x Height):	75 mm x 79 mm	75 mm x 105 mm
Housing:		PA-GF, high impact
Lens:		PC, transparent; Ring: PC /ABS-Blend
Connection:		CAGE CLAMP® technology max. 1.5 mm <sup>2</sup>
Cable entry:	Cable diameter max. 10 mm	Cable diameter 3-6 mm
Fixing:	Base mounting with flat seal	Bracket mounting incl. cable gland M12 x 1.5 mm
Life duration:		Up to 100,000 hrs

**Base mounting 221**

Voltage:	24 V AC/DC	115 V AC	230 V AC
Current consumption:	45 mA	25 mA	25 mA
red	221 100 75	221 100 67	221 100 68
green	221 200 75	221 200 67	221 200 68
yellow	221 300 75	221 300 67	221 300 68

**Bracket mounting 224**

Voltage:	24 V AC/DC	115 V AC	230 V AC
Current consumption:	45 mA	25 mA	25 mA
red	224 100 75	224 100 67	224 100 68
green	224 200 75	224 200 67	224 200 68
yellow	224 300 75	224 300 67	224 300 68

**TECHNICAL DIAGRAMS:**

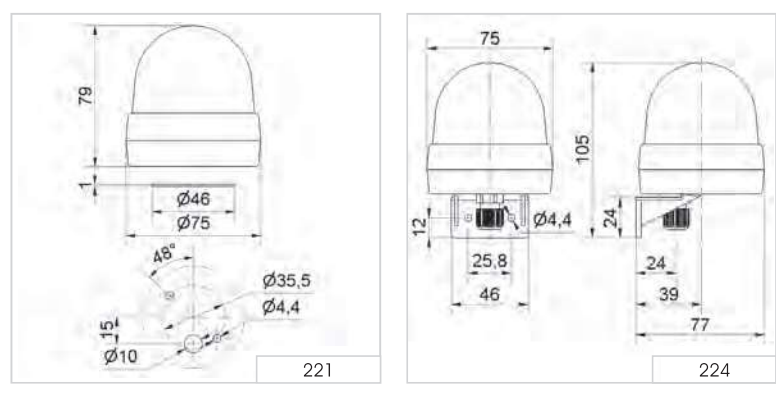

**Signalisation index**

LED Permanent Light 3

Base mounting 108 g Bracket mounting 114 g IP65 +50°C -20°C 24 V PLC

