



i TECHNICAL SPECIFICATIONS/ORDER SPECIFICATIONS:

Dimensions (Ø x Height):	142 mm x 218 mm		
Housing:	PC/ABS-Blend		
Lens:	PC, transparent		
Fixing:	Base mounting, Bracket/Tube mounting (accessory)		
Cable entry:	Cable diameter 5-7 mm		
Connection:	Screw terminal 0.5 - 1.5 mm ²		
Flash energy:	15 Ws		
Flash frequency:	C. 1 Hz		
Life duration:	4 x 10 ⁶ flashes		
Voltage:	24 V DC	115 V AC	230 V AC
Current consumption:	800 mA	400 mA	200 mA
red	838 100 55	838 100 67	838 100 68
yellow	838 300 55	838 300 67	838 300 68



Wire guard (accessory)

ACCESSORIES:

Plastic bracket for wall mounting	975 883 06
Adaptor for tube mounting	975 883 09
Wire guard, only for base mounting	975 883 08

TECHNICAL DIAGRAM:

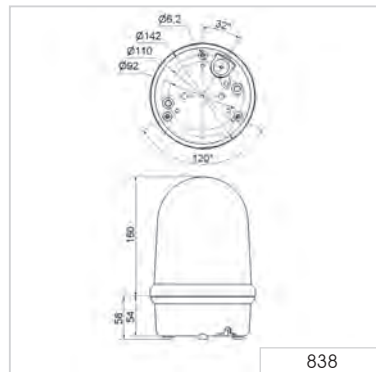

Adaptor for tube mounting and plastic bracket (accessories)

Signalisation index	
Xenon Flashing Light	9

