



**i TECHNICAL SPECIFICATIONS/ORDER SPECIFICATIONS:**

<b>Dimensions (L x H x W):</b>	168 mm x 168 mm x 155 mm	
<b>Housing:</b>	PC/ABS-Blend	
<b>Connection:</b>	Screw terminal 0.5 - 2.5 mm <sup>2</sup>	
<b>Cable entry:</b>	Cable gland M20 x 1.5 mm (not included in assembly)	
<b>Tone types and frequencies:</b>	Selectable via DIP switch, see table on page 248	
<b>Voltage:</b>	18-30 V DC	115/230 V AC
<b>Current consumption:</b>	450 mA	130 mA (115 V) / 65 mA (230 V)
red	<b>142 000 55</b>	<b>142 000 68</b>
grey	<b>142 100 55</b>	<b>142 100 68</b>

**ACCESSORIES:**

Cable gland M20 x 1.5 mm	<b>975 444 01</b>
--------------------------	-------------------

**TECHNICAL DIAGRAM:**

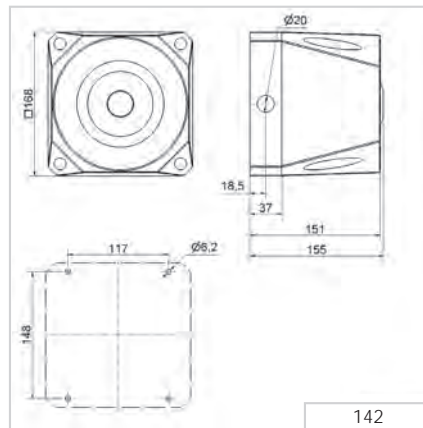

Signalisation index	
Multi-tone sounder	10

142 X00 68    142 X00 55



The 142 Multi-Tone Sounder offers a large choice of internationally recognised signal tones for the widest spectrum of applications. The first two tones can be freely chosen. The third tone is paired with the second tone.

**TONE TYPES AND FREQUENCIES:**

Tone 1+2 No	Tone type	Use	Output (dBA)	Tone 3
1	alternating 800/970 Hz in 2 Hz stroke (250 ms-250 ms)		120	14
2	rising 800/970 Hz in 7 Hz stroke (7/s)		120	14
3	rising 800/970 Hz in 1 Hz stroke (1/s)		120	14
4	continuous 2,850 Hz		111	9
5	rising 2,400-2,850 Hz in 7 Hz stroke		109	4
6	rising 2,400-2,850 Hz in 1 Hz stroke		110	4
7	500-1,200 Hz rising in 3 sec., 0.5 sec. OFF	Slow Whoop Holland	119	14
8	falling 1,200-500 Hz in 1 Hz stroke	DIN/PFEER (PAPA), DIN 33404-3, VDS tested	119	14
9	alternating 2,400/2,850 Hz in 2 Hz stroke (250 ms-250 ms)		113	4
10	pulse 970 Hz in 0,5 Hz stroke (1 sec. ON / 1 sec. OFF)	PFEER Alarm	117	14
11	alternating 800/970 Hz in 1 Hz stroke (500 ms-500 ms)		118	14
12	pulse 2,850 Hz in 0.5 Hz stroke (1 sec. ON / 1 sec. OFF)		112	4
13	970 Hz pulse: 0.25 sec. ON / 1 sec. OFF		117	14
14	continuous 970 Hz	PFEER - Toxic gas	118	8
15	554 Hz/100 ms alternating 440 Hz/400 ms	French alarm signal AFNOR NFS 32 S 32-001	115	14
16	660 Hz pulse: 150 ms ON, 150 ms. OFF	Swedish alarm signal	114	14
17	660 Hz pulse: 1.8 sec. ON, 1.8 sec. OFF	Swedish alarm signal	115	14
18	660 Hz pulse: 6.5 sec. ON, 13 sec. OFF	Swedish alarm signal	115	14
19	continuous 660 Hz	Swedish alarm signal	116	1
20	alternating 554/440 Hz in 0.5 Hz stroke (1 sec. ON / 1 sec. OFF)	Swedish alarm signal	115	19
21	pulse 660 Hz in 1 Hz stroke (500 ms-500 ms)	Swedish alarm signal	115	4
22	pulse 2,850 Hz in 4 Hz stroke (150 ms ON / 100 ms OFF)		110	4
23	rising 800-970 Hz in 50 Hz stroke		117	14
24	rising 2,400-2,850 Hz in 50 Hz stroke		110	4
25	970 Hz puls.: 3 x 500 ms. ON, 500 ms OFF, break 1.5 sec.	ISO 8201 / US Temporal	118	14
26	2,850 Hz puls.: 3 x 500 ms. ON, 500 ms OFF, break 1.5 sec.	ISO 8201 / US Temporal	112	4
27	continuous 4,000 Hz		105	6
28	alternating 800/970 Hz in 2 Hz stroke (250 ms-250 ms)		118	14
29	alternating 990/650 Hz in 2 Hz stroke (250 ms-250 ms)		117	14
30	alternating 510/610 Hz in 2 Hz stroke (250 ms-250 ms)		116	14
31	rising 300-1,200 Hz in 1 Hz stroke		118	14
32	continuous Bell		117	3
33	continuous Bell: 3x500 ms. Pulse, 1.5 sec. Silence, then repeat	Bell / US Temporal	117	14
34	alternating 1,000/2,000 Hz in 1 Hz stroke (500 ms-500 ms)	Singapore	115	4
35	pulse 420 Hz (0,625 sec.)	Australian alarm signal	118	14
36	500-1,200 Hz rising in 3,75 sec., then 0,25 sec. OFF	Australian alarm signal (Evacuation)	117	14
37	rising 1,400-1,600 Hz in 1 sec., falling in 0.5 sec.	NF C 48-265	116	14
38	500-1,200 Hz rising and falling 3 sec.	Siren	117	14
39	pulse 720 Hz: 0.7 sec. ON, 0.3 sec. OFF	German industrial alarm	118	14
40	rising 422-775 Hz in 0.85 sec., 1 sec. silence, then repeat	NFPA Whoop	118	14
41	continuous 470 Hz	Horn (USA)	114	3
42	continuous 370 Hz	Air Horn (USA)	113	3

