



**i TECHNICAL SPECIFICATIONS/ORDER SPECIFICATIONS:**

**Dimensions** (Ø x Height): 29 mm x 32 mm (Protrusion from panel)  
**Housing:** PC/ABS-Blend  
**Lens:** PC, transparent  
**Connection:** 2 wires, c. 600 mm long  
**Fixing:** Installation mounting for Ø 22.5 mm (M22 x 1.5 mm) with anti-twist device  
**Flash frequency:** 1.5 Hz  
**Flash energy:** 1 Ws  
**Life duration:** 4 x 10<sup>6</sup> flashes  
 Nut and seal included in assembly.

<b>Voltage:</b>	24 V AC/DC (10-100 V DC) (20-72 V AC)	115 V AC	230 V AC
<b>Current consumption:</b>	140 mA	30 mA	20 mA
red	<b>232 100 55</b>	<b>232 100 67</b>	<b>232 100 68</b>
yellow	<b>232 300 55</b>	<b>232 300 67</b>	<b>232 300 68</b>

**TECHNICAL DIAGRAM:**

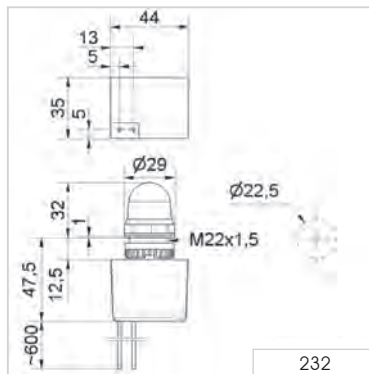

Signalisation index	
Xenon Flashing Light	4

