

AndonSPEED / Andon product

Andon SmartBOX BWM 115-230VAC BK



Part No.: 860.000.09



MECHANICAL DATA

Length	92 mm
Width	32 mm
Height	160 mm
Materials	PA-GF
Housing colour	Black
Protection category	IP30
Connection	Special version
cross-sectional area minimum	0,34mm ² / 22AWG
cross-sectional area maximum	1,00mm ² / 18AWG
Cable length	5000 mm
Tension relief	Present (conforms to VDE)
Type of fixing	Base mounting Wall mounting
Working temperature minimum	0°C
Working temperature maximum	+40°C
Weight with packaging	657 g
Product weight	586 g

ELECTRICAL DATA

Operating voltage	115-230V
Operating voltage type	AC
Operating voltage frequency	50Hz at 230V 60Hz at 115V
Operating voltage tolerance	+/- 10%
Rated operational voltage	230 VAC
Rated operational current	1000 mA
Protection class	Protection class 2
Pollution degree	2
Overtoltage category	II
Isolation voltage	Ui = 250V; Uimp = 2.500V

OPTICAL DATA

Service life optical	5,000 h minimum
----------------------	-----------------



For additional installation and mounting information, refer to the appropriate user guide at www.werma.com. This printed copy is for information only and is subject to alteration.

AndonSPEED / Andon product

Andon SmartBOX BWM 115-230VAC BK

DRAWING

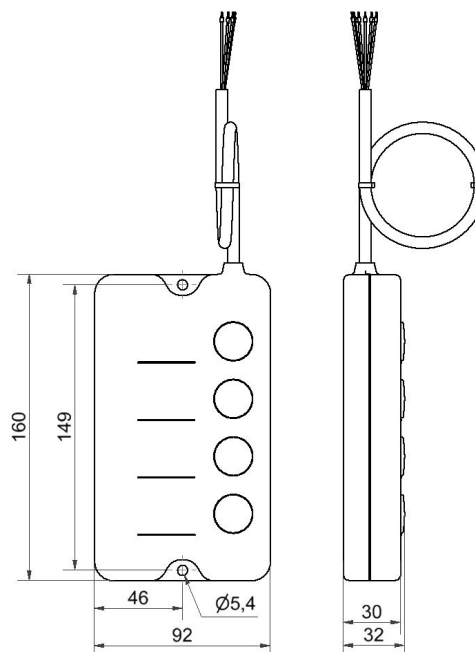

For additional installation and mounting information, refer to the appropriate user guide at www.werma.com. This printed copy is for information only and is subject to alteration.