



Installation use and maintenance



(Original instructions)



Safety Relay Module

SR X

SAFETY RELAY MODULE

TABLE OF CONTENTS

OVERVIEW	3
NEW SAFETY PARAMETERS FOR TYPE 2 BARRIERS AND MANDATORY LABELLING.....	4
OPERATING MODES DESCRIPTION	5
AUTOMATIC MODE.....	5
MANUAL MODE.....	6
CONNECTION OF EXTERNAL CONTACTORS K1 AND K2	7
CONNECTON EXAMPLES.....	8
CONNECTION OF SR X WITH 2 PAIRS OF PHOTOCELLS (WITHOUT K1K2 EXTERNAL CONTACTORS)	8
CONNECTION OF SR X WITH 1 PAIR OF PHOTOCELLS (WITH K1K2 EXTERNAL CONTACTORS).....	9
SERIES CONNECTION OF SR X WITH 2 PAIRS OF PHOTOCELLS (WITH K1K2 EXTERNAL CONTACTORS).....	9
CONNECTION OF SR X WITH 4 PAIRS OF PHOTOCELLS (WITHOUT K1-K2 EXTERNAL CONTACTORS).....	10
ELECTRICAL CONNECTIONS.....	11
INSTRUCTIONS CONCERNING CONNECTION CABLES.....	11
PINOUT	12
CHECKLIST AFTER INSTALLATION	12
INPUT and OUTPUT	13
THE RESTART COMMAND	13
THE SYS TEST COMMAND INPUT	13
SYS STATUS OUTPUT.....	13
CHARACTERISTICS OF THE OUTPUT CIRCUIT.....	14
USE OF K1 AND K2 AUXILIARY CONTACT ELEMENTS.....	14
K1 K2 FBK INPUT (EDM)	14
STATUS INDICATORS / FAULT DIAGNOSIS	15
NORMAL OPERATION.....	15
FAULT DIAGNOSIS.....	15
TECHNICAL DATA.....	16
DIMENSIONS.....	17
INDICATIONS AND INFORMATION FOR ENVIRONMENTAL PROTECTION.....	18
WARRANTY.....	19
EC DECLARATION OF CONFORMITY	20
UKCA DECLARATION OF CONFORMITY	21

 This symbol indicates an important personal safety warning. Failure to comply with the warning may result in very high risk for exposed personnel.

 This symbol indicates an important warning.

OVERVIEW

The SR X Safety Relay module is a safety device complying with EN 61496-1, EN 61496-2 specifications.

When connected to an ILION or a ULISSE UPC safety photocell, it forms a type 2 ESPE (Electro-sensitive Protective Equipment).

The SR X main features are the following:

- Possible connections: from 1 to 4 photocells
- Restart manual or automatic selectable
- 2 N.O. outputs with guided contact safety relays
- 1 system status PNP output
- 1 external contactors feedback input (EDM)
- Periodic self-test (every 5s) of the connected safety photocells

The Safety Relay Module also guarantees that:

- The output lines are open if the connected device is in OFF status;
- The output lines are enabled only with correct response times;
- In MANUAL mode, maintenance of the RESTART contact closed is not interpreted as AUTOMATIC mode.

 For safe use of the SR X module, it is essential to read and understand the contents of this handbook.

 Failure to comply with the prescriptions indicated in this handbook may result in very high risks for the operating personnel of the machine protected.

 Carefully consider the risks analysis of the application and the legislation of the barrier application Country to establish if the application is compatible with the safety category 2.

NEW SAFETY PARAMETERS FOR TYPE 2 BARRIERS AND MANDATORY LABELLING

- ➔ With the publication of Edition 3 of the harmonized EN 61496-1 standard it is no longer possible to use a Type 2 safety light barrier for safety functions assessed as SIL 2 / PL d.
- ➔ If a safety level of SIL 2 / PL d (or higher) is required and it is nevertheless intended to use a safety light barrier, then it will be necessary to use a Type 4 safety light barrier.
- ➔ This regulatory requirement derives from the fact that the reduction of risk that can be obtained via a photoelectric safety barrier is not only a function of the safety level of its electronic parts but is also determined by its systematic capabilities (for example: environmental influences, EMC, optical performance, and detection principle).
- ➔ The systematic capability of a Type 2 photoelectric barrier may in fact not be sufficient to ensure adequate risk reduction for SIL 2 / PL d applications.
- ➔ The standard also establishes that the labelling of Type 2 safety barriers must indicate such limitation to SIL 1 / PL c.
- ➔ The PFHd values declared for the electronic control part of the device, on the other hand, are not limited and therefore it is possible to use the PFHd value provided by the manufacturer of the device in the global assessment of the safety function, even if it exceeds the SIL 1 / PLc range.

OPERATING MODES DESCRIPTION

OPERATING MODES SELECTION		
TERMINAL 5	TERMINAL 6	OPERATION
0 VDC	+24 VDC	Automatic
+24 VDC	0 VDC	Manual
0 VDC	0 VDC	Non-permissible conditions
+24 VDC	+24 VDC	

Table 1

AUTOMATIC MODE

In this operating mode, the outputs of the Safety Relay Module follow the status of the photocell:

- with the protected area free (outputs of the photocells active), the relay outputs of the Safety Relay Module are active.
- with the protected area occupied (outputs of the photocells de-activated), the relay outputs of the Safety Relay Module are de-activated.

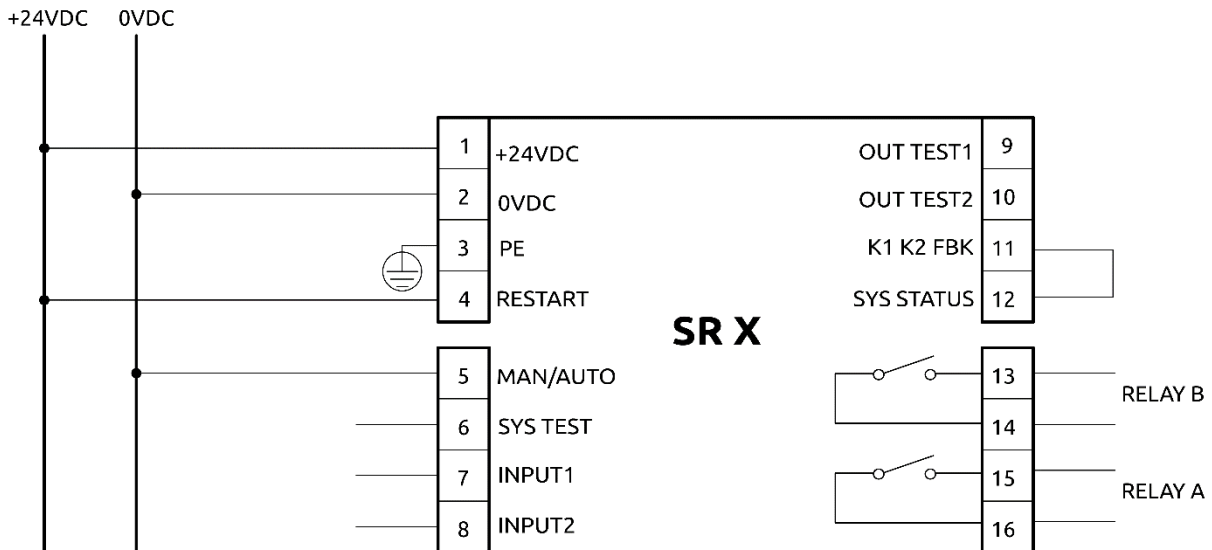

Figure 1 – Automatic operation without K1 K2 relays

- ☠ Use in manual mode (start/restart interlock activated) is mandatory in case the safety device controls an access protecting a danger zone and once a person has passed through the opening, he/she may remain in the danger zone without being detected (use as trip device according to EN 61496). Failure to comply with this rule may result in very serious risks for the persons exposed.
- ☠ Check correct operation of the entire safety system (safety relay + photocell) following each re-installation.
- ☠ When the K1-1 and K2-1 N.C. control contacts are not used (or no control is provided) it is mandatory to connect the terminal 11 (K1K2 FBK) to terminal 12 (SYS STATUS).

MANUAL MODE

In this operating mode, the outputs of the safety relay are activated only if the protected area is free and after sending the RESTART signal to the unit using the push-button or by means of a specific command on the RESTART input (terminal 4).

- ➔ Refer to the “THE RESTART COMMAND” at page 13 for a more detailed description of the command.
- ➔ Once the protected area has been occupied, the output relays are de-activated.
- ➔ The sequence described on “THE RESTART COMMAND” section must be repeated in order to re-activate the outputs relay.

⚠ Check correct functioning of the entire safety system (safety relay + barrier) following each re-installation. If the original operating mode was Manual, check that the unit has been reconfigured in this mode.

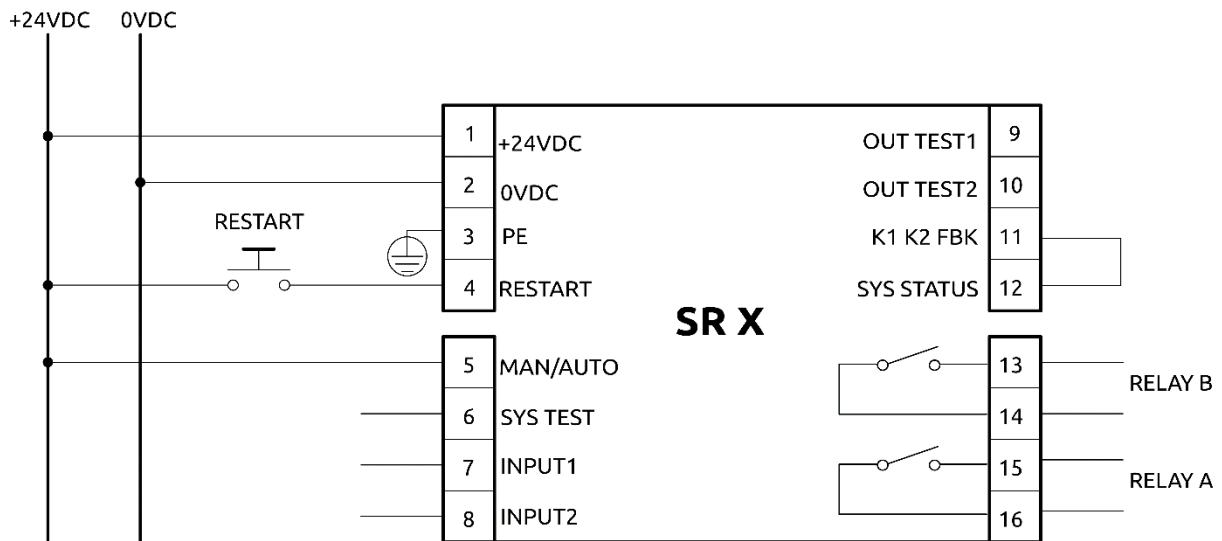

Figure 2 – Manual operation without K1 K2 relays

⚠ When the K1-1 and K2-1 N.C. control contacts are not used (or no control is provided) it is mandatory to connect the terminal 11 (K1 K2 FBK) to terminal 12 (SYS STATUS).

CONNECTION OF EXTERNAL CONTACTORS K1 AND K2

Control of external contactors K1 K2 can be activated in both operating modes. If this control must be used, the series of normally closed contacts of the external contactors must be connected to terminal 11 of the Safety Relay Module (Figure 3 and Figure 4).

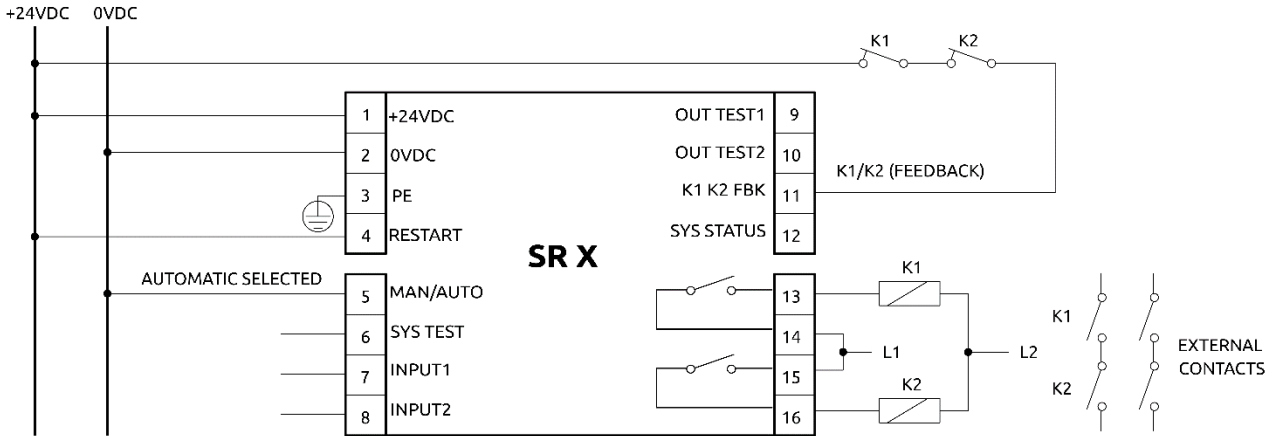

Figure 3 – Automatic operation with K1 K2 relays

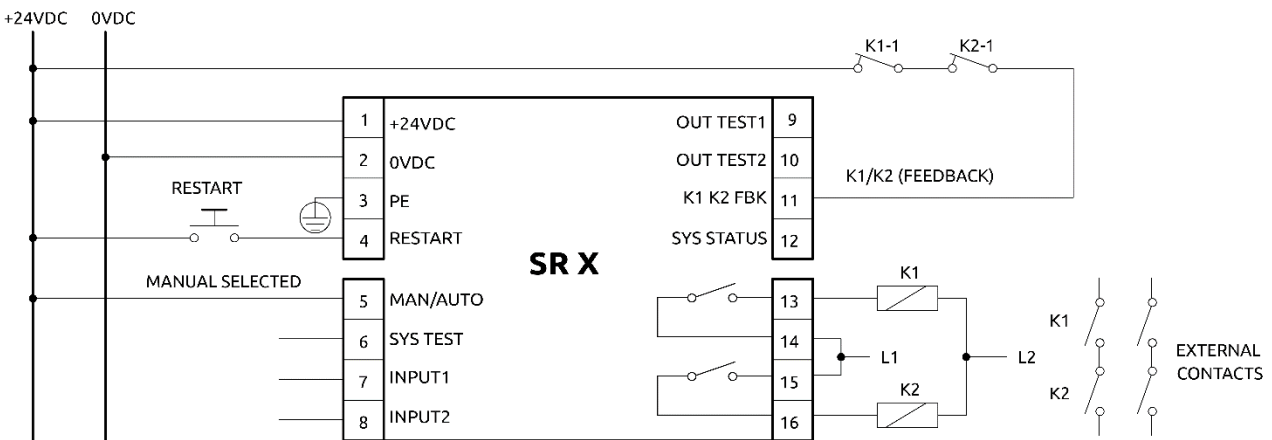

Figure 4 – Manual operation with K1 K2 relays

CONNECTON EXAMPLES

Connection of SR X with 2 pairs of photocells (without K1K2 external contactors)

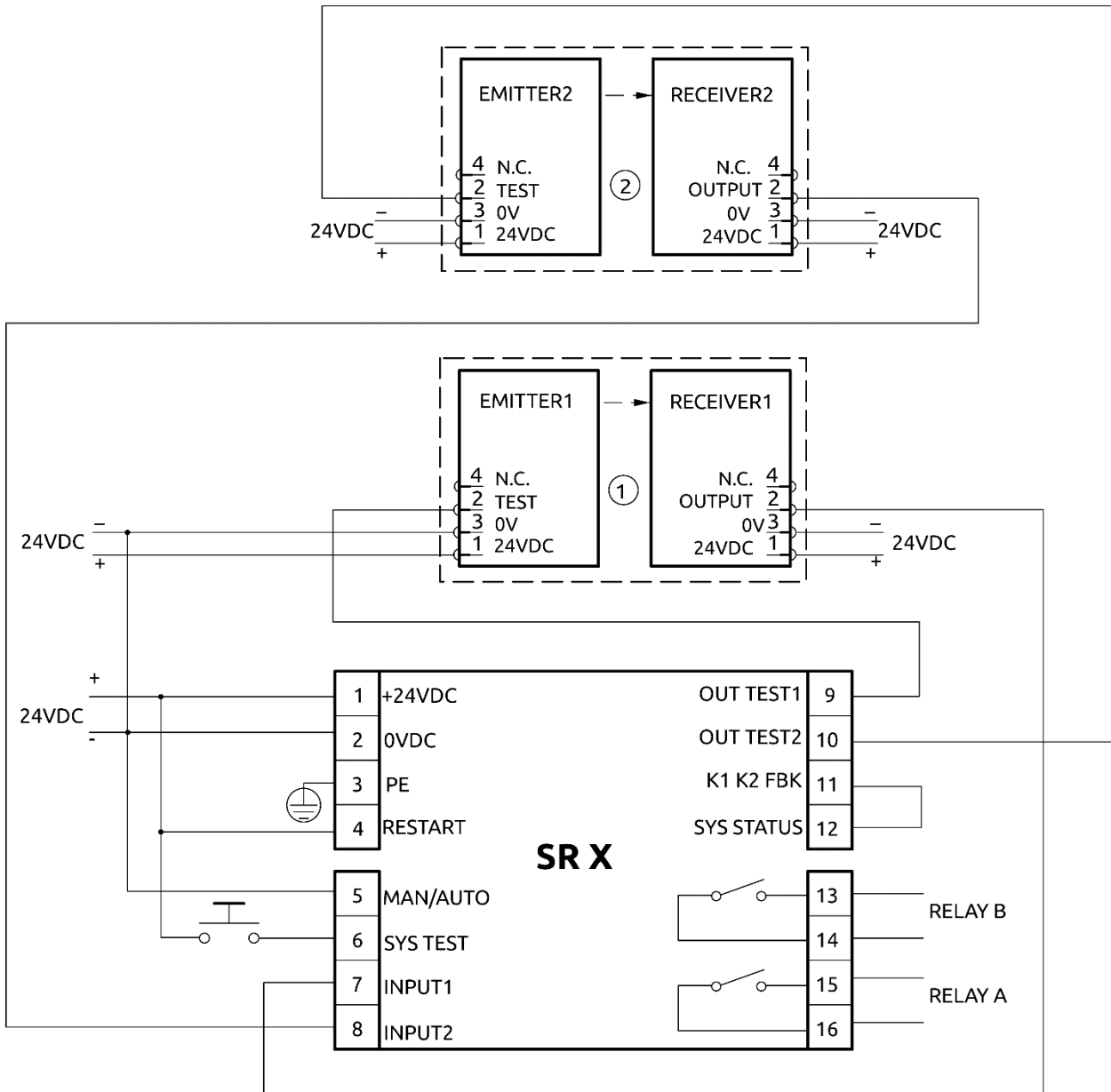

Figure 5

Connection of SR X with 1 pair of photocells (with K1K2 external contactors)

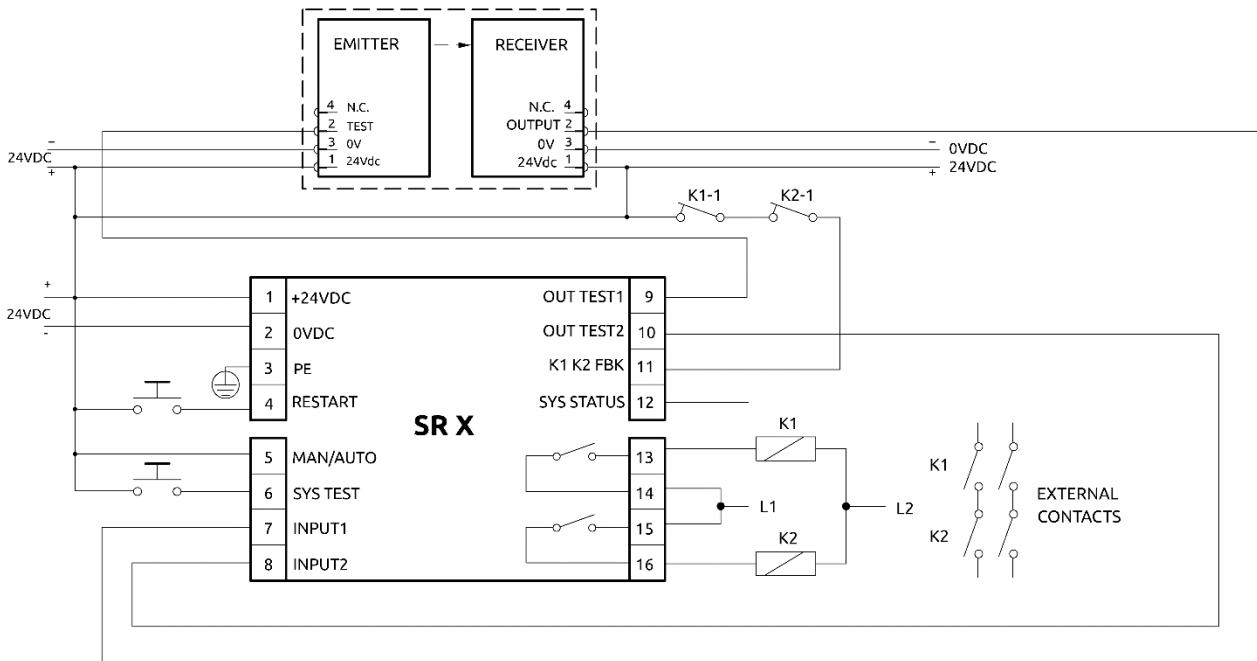

Figure 6

Series connection of SR X with 2 pairs of photocells (with K1K2 external contactors)

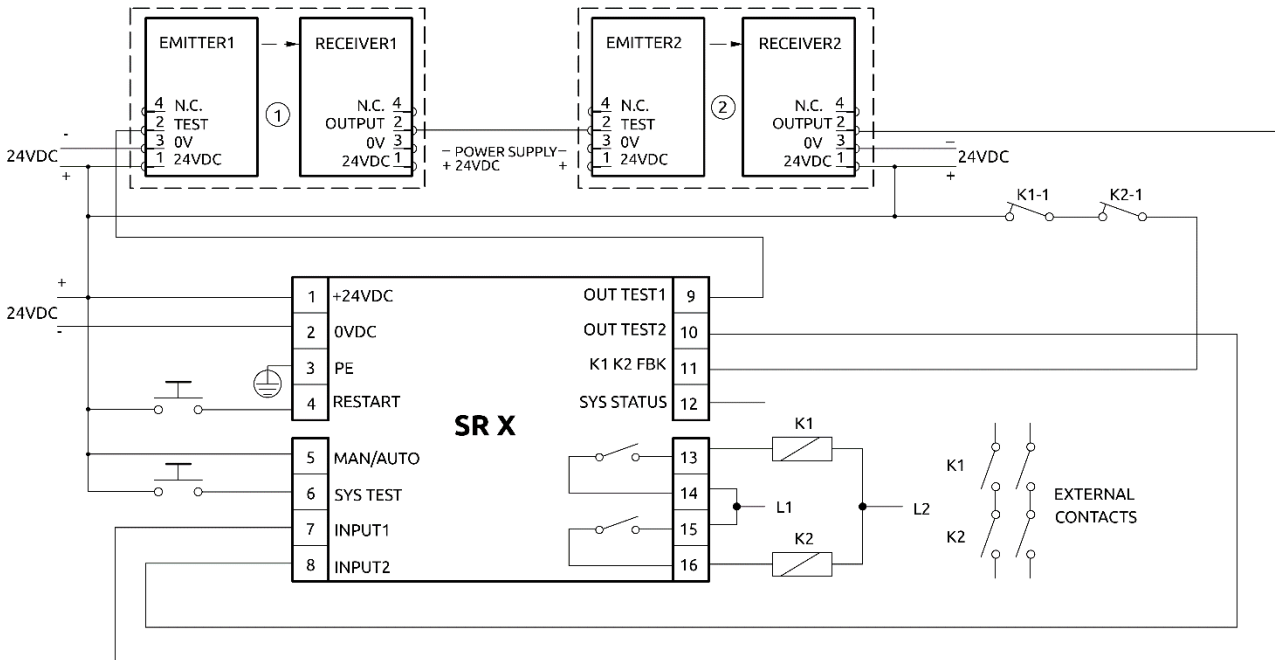

Figure 7

➔ In this case, the 2 photocells are connected in series and the module INPUT2 (terminal 8) is not utilized; this signal must be connected to the OUT TEST2 (terminal 10).

Connection of SR X with 4 pairs of photocells (without K1-K2 external contactors)

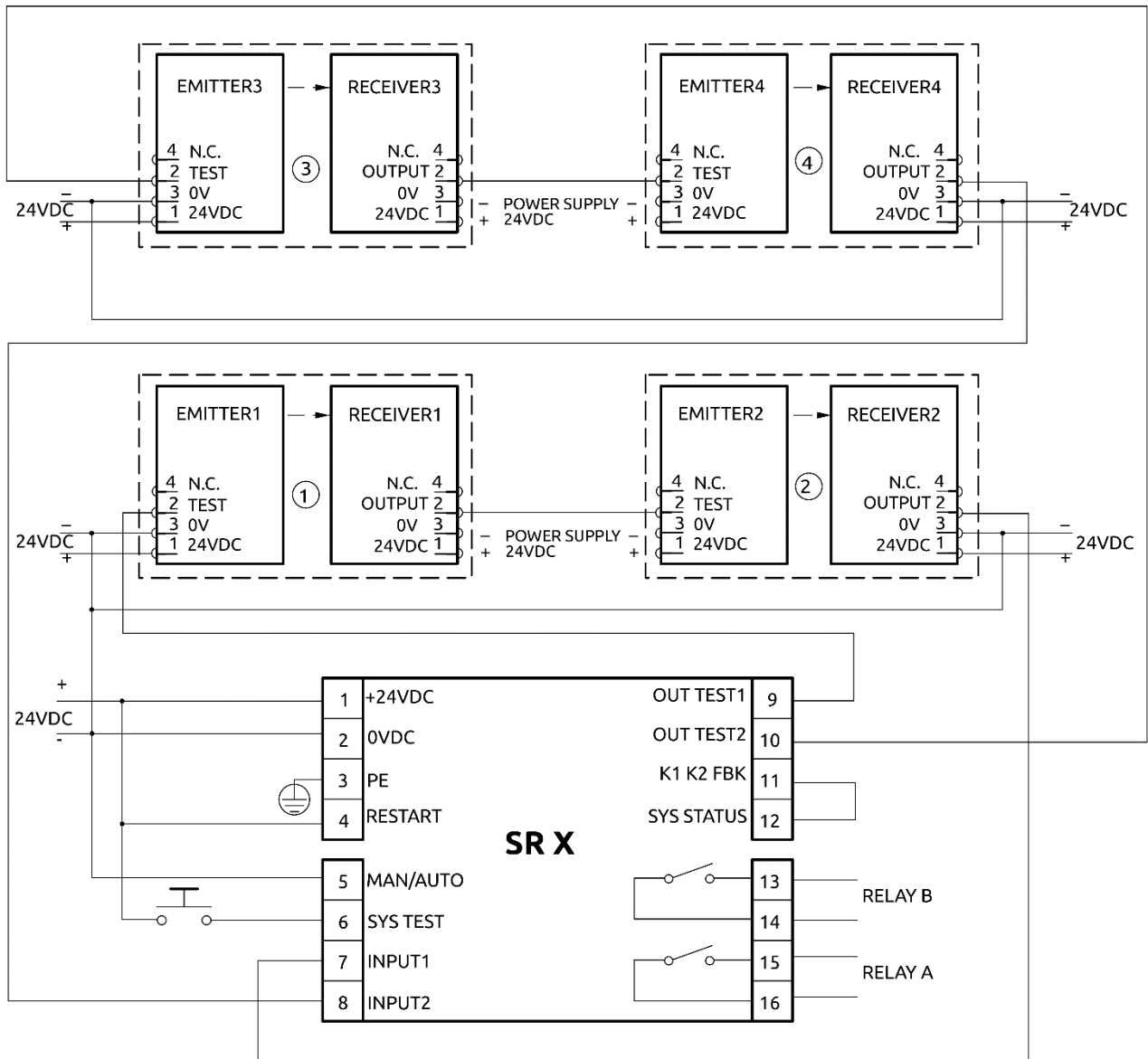

Figure 8

ELECTRICAL CONNECTIONS

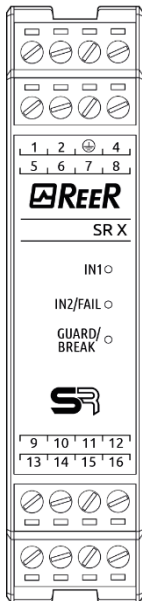

Figure 9

SR X is provided with terminal blocks for the electrical connections.
The unit provides 16 terminals.

→ Terminal tightening torque: 5...7lb-in (0,6...0,7 Nm).

- ⚡ Install the SR X Safety Relay Module in an environment with a protection rating of at least IP54.
- ⚡ If more modules SR X must be installed in the same board panel, in order to avoid overheating, maintain between them one minimal distance of 2cm.
- ⚡ The supply voltage must be $24 \pm 20\%$ VDC; PELV (in compliance with the standard EN 60204-1 (Chapter 6.4)).
- ⚡ During the installation of the SR X Safety Relay Module be sure to avoid short circuits between the contacts 7 and 8.
- ⚡ Connect the Safety Relay Module when it is not powered.
- ⚡ Do not use the SR X to supply external devices.
- ⚡ The same ground connection (0VDC) must be used for all system components.

INSTRUCTIONS CONCERNING CONNECTION CABLES.

- Wire size range: AWG 12...30, (solid/stranded) (UL).
- Use 60/75°C copper (Cu) conductor only.
- We recommend the use of separate power supplies for the safety controller and for other electrical power equipment (electric motors, inverters, frequency converters) or other sources of disturbance.
- Cables used for connections longer than 50m must have a cross-section of at least 1mm² (AWG16).

PINOUT

TERMINAL NUMBER	SIGNAL NAME	TYPE OF SIGNAL	DESCRIPTION
1	24VDC		Power supply 24VDC
2	0VDC		Power supply 0VDC
3	PE	-	Ground connection
4	RESTART	Input	Restart command
5	MAN/AUTO	Input	Manual/Automatic Configuration
6	SYS TEST	Input	System Test external request
7	INPUT1	Input	Safety Input 1
8	INPUT2	Input	Safety Input 2
9	OUT TEST1	Output	TEST Output n°1 for safety photocell
10	OUT TEST2	Output	TEST Output n°2 for safety photocell
11	K1 K2 FBK	Input	Feedback external contactors K1 K2
12	SYS STATUS	Output	Output Status
13	B NO1	Output	Safety relay B, contact 1 (N.O.)
14	B NO2	Output	Safety relay B, contact 2 (N.O.)
15	A NO1	Output	Safety relay A, contact 1 (N.O.)
16	A NO2	Output	Safety relay A, contact 2 (N.O.)

Table 2

CHECKLIST AFTER INSTALLATION

The SR X Safety Relay Module is able to detect in real time the faults.

To guarantee the system perfect operation perform the following checks at start up and before each work shift:

OPERATION / CONTROL	COMPLETE
1. Verify the correct fixing of SR X to the Omega rail.	<input type="checkbox"/>
2. Verify that all the cables are correctly inserted and the terminal blocks well screwed.	<input type="checkbox"/>
3. Verify that all the LEDs (indicators) light on correctly.	<input type="checkbox"/>
4. Verify the correct positioning of the safety photocells connected to SR X.	<input type="checkbox"/>
5. Verify that all the external indicators (lamps) work properly.	<input type="checkbox"/>
6. Operate a complete System Test.	<input type="checkbox"/>

The System Test is mandatory because a type 2 device is connected upstream to SR X safety module (e.g., photocell, etc). Refer to the *"THE SYS TEST COMMAND"* section.

INPUT AND OUTPUT

THE RESTART COMMAND

The RESTART command allows SR X to manage Manual operation.

- ➔ The RESTART command must be sent to SR X connecting terminal 4 to the 24VDC, respecting the behaviour of the timing beside.
- ➔ The contact used for the RESTART command must be able to switch a voltage of 24VDC and a current of 10mA (guaranteeing a closing time $t_1: 5s > t_1 > 100ms$).
- ➔ The whole SYSTEM RESET TIME is obtained adding the reset time of any external contactors K1 K2 to the reset time of SR X.

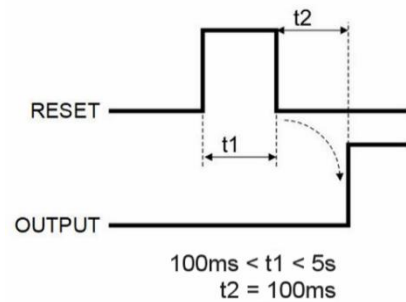

- This data is particularly important in the case of automatic management of the RESTART command sending, for example using a PLC.
- In the case of manual activation, a normally open external button can be used, temporary closing of which generates the RESTART command.

- ⚠ The Restart command must be installed outside the danger area in a position where the danger area and the entire work area concerned are clearly visible.
- ⚠ It must not be possible to reach the control from inside the danger area.

THE SYS TEST COMMAND INPUT

The SYS TEST command must be forwarded to the safety module connecting the terminal 6 to the +24Vdc.

The SYS TEST command must be sent to SR X connecting terminal 6 to the 24VDC for a time $t > 40 \text{ msec}$ and remains operative as long as the terminal 6 is connected to 24VDC.

The SR X safety module, after receiving this signal, provides to switch off the emitters of the connected safety photocells, THUS SIMULATING AN INTERCEPTION OF THE PROTECTED AREA.

- ⚠ The operator must verify the effective stopping of the hazardous machine (due to the de-activation of the safety module outputs) for all the time the SYSTEM_TEST command stays active.

SYS STATUS OUTPUT

The SYS STATUS output reports exactly the output safety relays status :

- When the output relays are opened, the SYSTEM STATUS reports 0VDC.
- When the output relays are closed, the SYSTEM STATUS reports +24VDC.

CHARACTERISTICS OF THE OUTPUT CIRCUIT

For the output circuit, the Safety Relay Module uses two guided contact safety relays.

These relays are rated by the manufacturer for voltage and current values above those indicated in the technical data; however, to assure correct insulation and to avoid damage or premature aging, protect each output line with an appropriate fuse (depending on the load). Check that load characteristics comply with the indications given in the table below.

Minimum switching voltage	18 VDC
Minimum switching current	20 mA
Maximum switching voltage	250 VAC
Maximum switching current	6A(AC) / 6A(DC)

USE OF K1 AND K2 AUXILIARY CONTACT ELEMENTS

For loads with higher voltage and current characteristics than those indicated in the table above, use of auxiliary external relays or contactors suitable for the load to be controlled is recommended.

- The K1 and K2 auxiliary contactors or relays must be of the guided contact safety type.
- Referring to the table below, pay particular attention to the configuration of the control contacts on terminal 11 and that of the contacts of use. (See K1 K2 FBK input (EDM), page 14).

	Relay K1	Relay K2
Control contacts	K1-1 normally closed	K2-1 normally closed
Use contacts	K1-2 normally open	K2-2 normally open

- Control contacts K1-1 and K2-1 (terminal 11) must be able to switch a current of 20mA and a voltage of 24VDC.
- To increase the electrical life of internal relays A and B, it is advisable to use anti-disturbance devices which must be connected across the coils of K1 and K2.

K1 K2 FBK INPUT (EDM)

Using the K1 and K2 auxiliary safety contactors with guided contact safety type, it is necessary to connect the +24VDC to the **K1 K2 FBK** through the series of the K1-1 and K2-1 N.C. control contacts.

→ The control of the correct switching of K1 and K2 is performed with a delay of 300ms.

If the application requires it, the response time of the external contactors must be verified by an additional device.

When the K1-1 and K2-1 N.C. control contacts are not used (or no control is provided) it is mandatory to connect the terminal 11 (K1 K2 FBK) to terminal 12 (SYS STATUS).

STATUS INDICATORS / FAULT DIAGNOSIS

NORMAL OPERATION

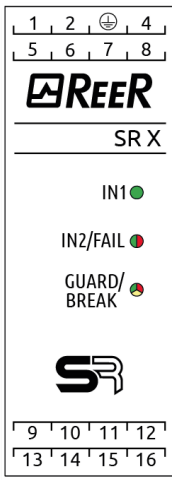

LED	COLOR	STATUS	CONDITION
IN1	Green	ON	Photocell 1 free
		OFF	Photocell 1 intercepted or not present
IN2/FAIL	Green/ Red	RED	Fault detected *
		GREEN	Photocell 2 free
		OFF	Photocell 2 intercepted or not present
GUARD/ BREAK	Green/ Red/ Yellow	RED	Output relays opened
		RED blinking	The number of blinkings shows the kind of FAIL (only with IN2/FAIL RED) *
		GREEN	Output relays closed
		YELLOW	Photocells free - Output relays opened module waiting for RESTART (only in MANUAL mode)

* REFER TO THE "FAULT DIAGNOSIS" SECTION TO HAVE A DETAILED EXPLANATION OF THE POSSIBLE FAULT

Table 3

FAULT DIAGNOSIS

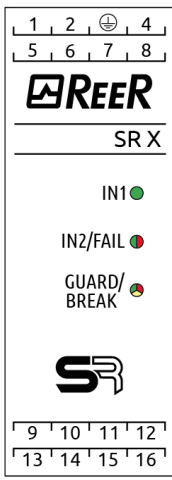

LED		GUARD/BREAK RED/GREEN (pulses red LED)	MEANING
IN GREEN	FAIL RED		
OFF	ON	(2 pulses)	<ul style="list-style-type: none"> Internal fault
OFF	ON	(3 pulses)	<ul style="list-style-type: none"> Internal relays fault
OFF	ON	(4 pulses)	<ul style="list-style-type: none"> K1 K2 external relays fault
OFF	ON	(5 pulses)	<ul style="list-style-type: none"> User configuration failure INPUT1/2 consistency check failed (<20ms) Check connected photocell outputs
OFF	ON	(6 pulses)	<ul style="list-style-type: none"> User configuration changed without system restart: Switch off and restart the module to solve the problem. At the switch on verify the new user configuration.
OFF	ON	(7 pulses)	<ul style="list-style-type: none"> Possible overload or SYSTEM STATUS connection error

Table 4

⚠ If it is not possible to clearly identify the malfunction and to remedy it, stop the machine and contact the Reer's After Sales Department.

TECHNICAL DATA

SAFETY DATA	VALUE	STANDARD
Safety level	Type 2	EN 61496-1: 2020
	SIL 1	EN 61508:2010
	SILCL 1	EN 62061:2005 / A2:2015
	Cat.2	EN ISO 13849-1: 2015
Device lifetime	20 years	EN ISO 13849-1: 2015
Certifications	cULus, TÜV	

Load	Number of Commutations	PFHd *	DCavg #	MTTFd #	PL #	CCF #
2A@230Vac	1 every 30s	1,73E-07	99,00%	25,16	d	80%
	1 every min	8,89E-08	99,00%	47,01	e	80%
	1 every hour	6,43E-09	98,97%	322,56	e	80%
	1 every day	5,12E-09	98,97%	355,69	e	80%
0,5A@24VDC	1 every 30s	3,41E-07	99,00%	13,04	d	80%
	1 every min	1,73E-07	99,00%	25,16	d	80%
	1 every hour	7,83E-09	98,97%	293,41	e	80%
	1 every day	5,21E-09	98,97%	353,27	e	80%

* EN 61508:2010, EN 62061:2005/A2:2015; # EN ISO 13849-1: 2015

ELECTRICAL PARAMETERS	VALUE
Power supply	24 ± 20% VDC; PELV
Rated impulse between PELV and relay contacts	6 kV
Power requirement	3W max
Protection	Overload protected STATUS output
INPUT DATA	VALUE
Number of connectable photocells	max 4
Inputs number/data (type 3)	5 / according to standard EN61131-2, type 3
Input current	Typical 4.3mA
Input voltage	0VDC...30VDC
Inputs number/data (type 2)	1 / according to standard EN61131-2, type 2
Input current	Typical 10mA
Number of EDM input	1 N.C. contact
System Test Input number/ value	1 / 20mA@24VDC
System Test response time	40ms
EDM response time	300ms
OUTPUT DATA	VALUE
Number of safety output	2 N.O. contacts
Type	Relays with forced guided contacts
Max switching voltage	250VAC , 125 VDC, Overvoltage Category III
Max switching current	6A (AC), 6A (DC)
Max switching power	1500VA, 180W (85W if load voltage >30VDC)
Max Response time	20ms
Mechanical service life	10 x 10E6
Electrical service life AC1 at 360 switchings/h	> 10E5
System Status Output number/ value	1 / 100mA@24VDC
CONNECTIONS / OPERATION	
Operating modes	Manual or Automatic, selectable from terminal block
Connections	16 Terminal block with protection against reversal of polarity
Status indicators	LED: Input – Output Status – Fail
Max. length of connections	100m
Operating temperature	-30...55°C
Max surrounding air temperature	55°C
Storage temperature	-30...70°C
Relative humidity	10%...95%
Maximum operating altitude	2000m
Vibration resistance (CEI EN 60068-2-6:2009)	+/- 1.5 mm 9...200 Hz
Bump resistance (CEI EN 60068-2-27:2012)	15 g (6 ms half-sine)

ENCLOSURE DATA	VALUE
Description	Electronic housing 16 pole, with locking latch mounting
Enclosure protection rating	IP 20
Terminal block protection rating	IP 2X
Fastening	Fast attachment to rail according to CEI EN 60715
Dimensions (h x w x d)	99mm x 22,5mm x 113,5mm
Weight	150g

DIMENSIONS

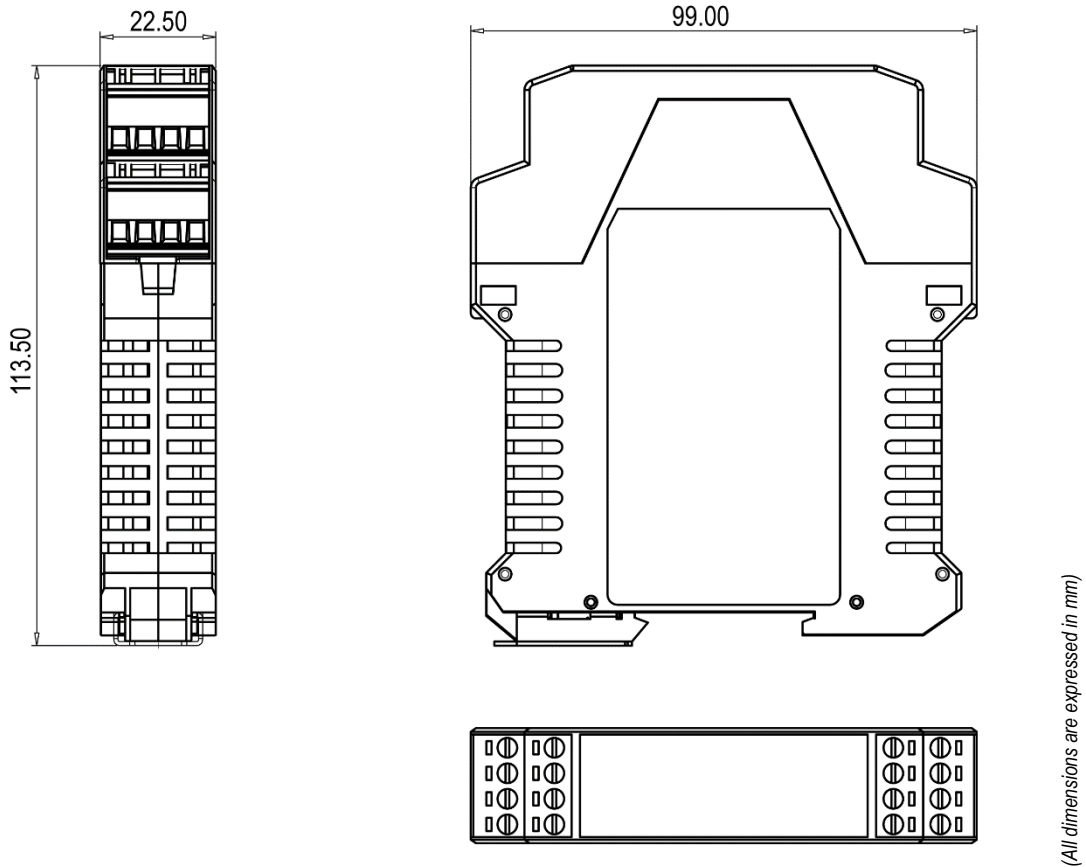
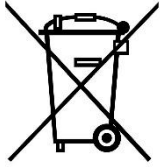

Figure 10

INDICATIONS AND INFORMATION FOR ENVIRONMENTAL PROTECTION

Dispose of the product in an eco-compatible manner and in accordance with national legislation.

**For Countries in the European Union:**

Pursuant to the Directive no. 2012/19/EU on waste electrical and electronic equipment (WEEE).

The crossed out wheeled-bin symbol on the equipment or its packaging means that when the product reaches the end of its useful life it must be collected separately from other waste.

Proper separate collection of the discarded equipment for later environment-friendly recycling, processing, and disposal, helps to avoid any negative impact on the environment and health and encourages re-use and recycling of the materials the equipment is made of.

In each individual Member State of the European Union this product is required to be disposed of in accordance with Directive 2012/19/EU as implemented in the Member State where the product is disposed of.

For further information please contact Reer or your local dealer.

WARRANTY

ReeR warrants that each SR X unit in new ex-factory condition, in conditions of normal use, is free of defects in the materials and of manufacturing defects for a period of 12 (twelve) months.

In this period, ReeR undertakes to eliminate any faults in the product through repair or replacement of the faulty parts, completely free of charge as regards material and labour. However, ReeR reserves the right to replace the entire faulty appliance with another equivalent appliance or with the same characteristics instead of repairing this.



Validity of this warranty is regulated by the following conditions:

- The user must inform ReeR of the fault within twelve months from the date of delivery of the product.
- The appliance and its components must be in the conditions in which they were delivered by ReeR.
- The serial numbers must be clearly legible.
- The fault or defect has not been caused directly or indirectly by:
 - Improper use;
 - Non-compliance with instructions for use;
 - Carelessness, inexperience, incorrect maintenance;
 - Repairs, modifications, adaptations not carried out by ReeR personnel, tampering, etc.;
 - Accidents or impacts (also due to transportation or causes of force majeure);
 - Other causes not to be ascribed to ReeR.

Repairs will be carried out at the ReeR laboratories to which the material must be delivered or dispatched: transport risks and the risks of any damage or loss of the material during shipment are the responsibility of the user.

All products and components replaced become the property of ReeR.

ReeR does not recognize any other warranties or rights except for those specifically described above; therefore, no claims for damages may be submitted for expenses, interruption of business or other factors or circumstances in any way related to failure of the product or of one of its parts.

-  Precise, complete compliance with all the rules, instructions and prohibitions indicated in this handbook is an essential requirement for correct functioning of the device.
-  ReeR s.p.a. therefore declines any responsibility for all and anything resulting from failure to comply, even partially, with such indications.

Characteristics subject to change without notice. • Total or partial reproduction is forbidden without the prior authorization of ReeR.

EC DECLARATION OF CONFORMITY**Dichiarazione CE di conformità
EC declaration of conformity**

Torino, 19/09/2022

REER SpA
via Carcano 32
10153 – Torino
Italy

dichiara che moduli di sicurezza **SR X / SR XM** unitamente ad un numero variabile da 1 a 4 sensori di sicurezza della serie **ULISSE UPC** o **ILION** costituisce un sistema Elettrosensibile di Sicurezza (ESPE) di:

- **Tipo 2** (secondo la Norma **EN IEC 61496-1:2020**)
- **SIL 1** (secondo la Norma **EN 61508: 2010**)
- **SILCL 1** (secondo la Norma **EN 62061: 2005 + A2:2015**)
- **PL c** (secondo la Norma **EN ISO 13849-1: 2015**)

declares that the safety interface **SR X / SR XM** together with 1,2,3 or 4 **ULISSE UPC** or **ILION** series safety sensors forms a type 2 Electro-sensitive Protective Equipment (ESPE) of :

- **Type 2** (according the Standard **EN IEC 61496-1:2020**)
- **SIL 1** (according the Standard **EN 61508: 2010**)
- **SILCL 1** (according the Standard **EN 62061: 2005 + A2:2015**)
- **PL c** (according the Standard **EN ISO 13849-1: 2015**)

realizzati in conformità alle seguenti Direttive Europee:
complying with the following European Directives:

- **2006/42/EC** "Direttiva Macchine"
"Machine Directive"
- **2011/65/EU** "RoHS – Linea Guida"
"RoHS – Guideline "
- **2014/30/EU** "Direttiva Compatibilità Elettromagnetica"
"Electromagnetic Compatibility Directive"

e alle seguenti Norme: /and to the following Standards:

- **EN 55032: 2015**
- **EN IEC 63000: 2018**

e sono identiche all'esemplare esaminato ed approvato con esame di tipo CE da:
and are identical to the specimen examined and approved with a CE - type approval by:

TÜV SÜD Product Service GmbH – Zertifizierstelle – Ridlerstraße 65 – 80339 – München – Germany
N.B. number: 0123 - Certificate number: Z10 024820 0085 Rev. 01

Responsabile per la documentazione tecnica:
Responsible person for technical documentation:

Carlo Pautasso

Carlo Pautasso
Direttore Tecnico
Technical Director

Simone Scaravelli
Amministratore Delegato
Managing Director

UKCA DECLARATION OF CONFORMITY

ReeR declares that SR X Safety Relay module complies with following UK legislation:

- S.I. 2008 No. 1597 - The Supply of Machinery (Safety) Regulations
- S.I. 2016 No. 1101 - Electrical Equipment (Safety) Regulations
- S.I. 2016 No. 1091 - Electromagnetic Compatibility Regulations
- S.I. 2012 No. 3032 - The Restriction of the Use of Certain Hazardous Substances in Electrical and Electronic Equipment Regulations

→ Please refer to the link <https://www.reersafety.com/certifications> to download the complete UKCA Declaration of Conformity.



Via Carcano, 32
10153 Torino, Italy
T +39 011 248 2215
F +39 011 859 867
www.reersafety.com
info@reer.it

All REER product manuals are available at URL <https://www.reersafety.com/it/en/download/manuals>

